

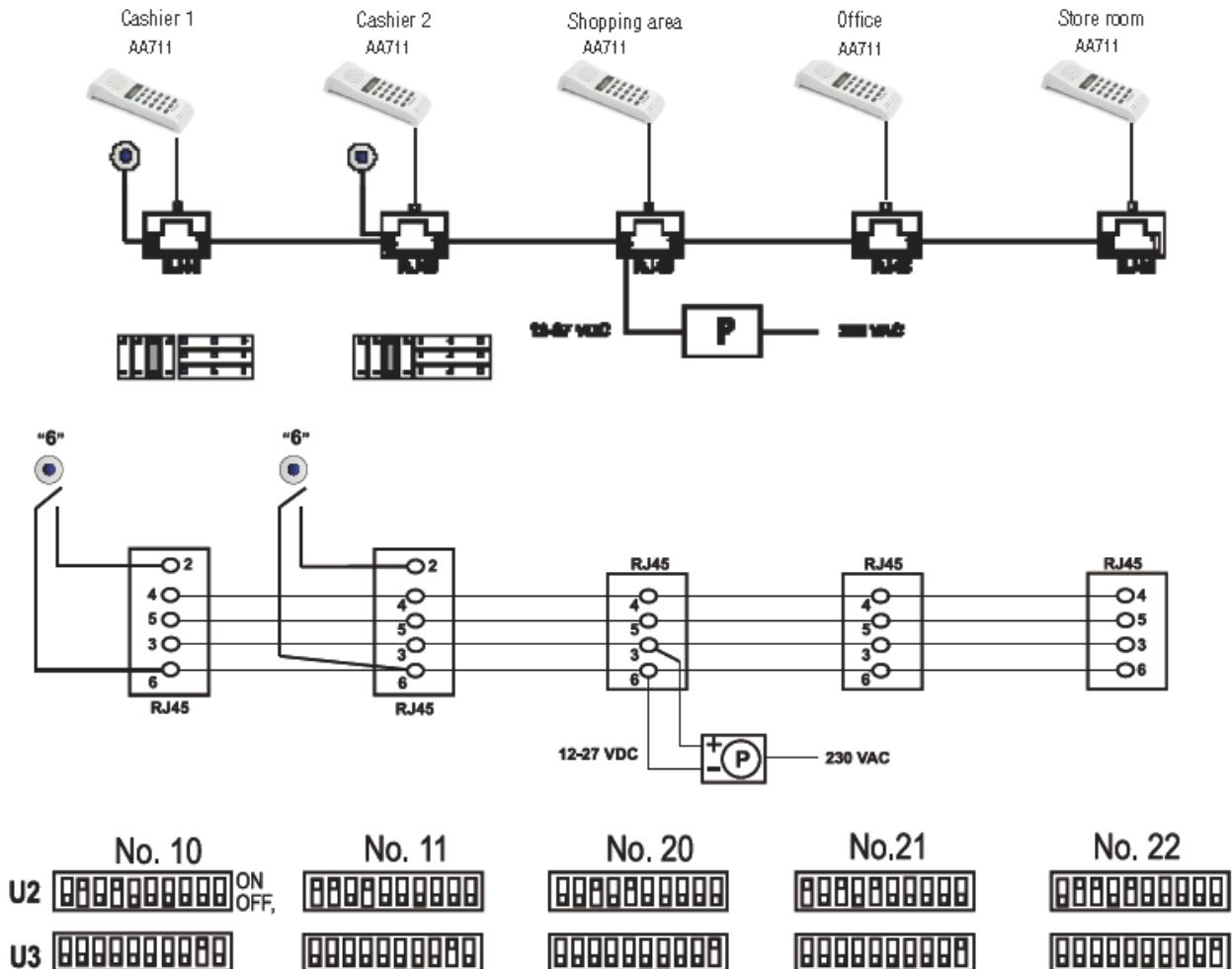

### SUPERMARKET

Cashiers Can Request Assistance For Prices, Money and Assistance, etc.



#### Description

P: Power supply. Should be located as close to the centre of the installation as possible.

All stations are programmed as direct dialling 10 keys stations.

All stations are programmed with priority.

The cashier stations are programmed to direct dial no.20 - 28.

Stations no. 20 - 28 are programmed to direct dial the cashier stations, no. 10 - 18.

An 'emergency' call can be made by pressing button 9.

The caller can speak as long as button 9 is pressed, and all stations will receive the message simultaneously.

The 'emergency call' will be cancelled automatically when button no.9 is released.

The 'emergency call' will automatically cancel an ongoing conversation, which has been established by pressing one of the buttons from 0 to 8 (direct dialling).

This example is only one of many possible configurations for a system in a supermarket.