

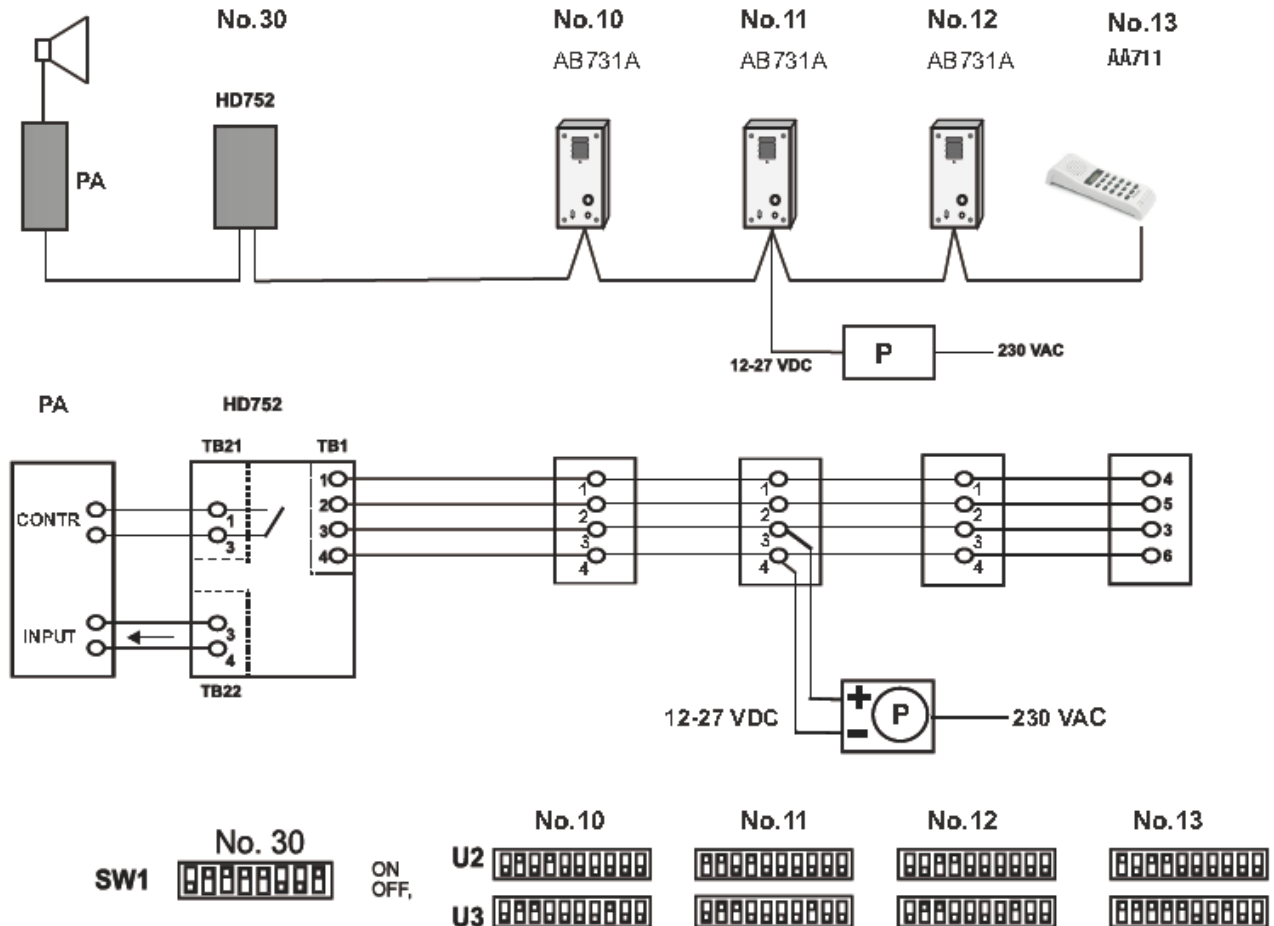

## LIFT COMMUNICATION SYSTEM

Guard Can Give Messages Via Pa System



### Description

P: Power supply

A gondola lift is located in the hills of a resort area. Sub stations are installed at important checkpoints, for communication with the guard in the control room (no.13).

The guard can dial no.30 to make an announcement via the PA system. Loudspeakers are mounted in each cable supporting tower.

All substations will be queued to the guard if more calls are made simultaneously.

We are using the CAS function for this operation.